



# ROITHNER LASERTECHNIK GmbH

WIEDNER HAUPTSTRASSE 76  
TEL. +43 1 586 52 43 -O. FAX. -44

1040 VIENNA AUSTRIA  
OFFICE@ROITHNER-LASER.COM



## LDM-0980-300M-92

- Laser Diode
- 975 nm, 300 mW
- Multi-Mode
- 9 mm TO-Can with PD



### Description

**LDM-0980-300M-92** is a **multi-mode** infrared laser diode, typically emitting at **975 nm**, with a nominal output power of **300 mW**, and maximum operating temperature range of **50°C**. **LDM-0980-300M-92** comes in hermetically sealed **9 mm TO-Can** package with AR coated flat glass window and **integrated monitor photodiode**.

### Maximum Ratings\*

Parameter	Symbol	Values		Unit
		Min.	Max.	
Operating Temperature	$T_{OPR}$	- 20	+ 50	°C
Storage Temperature	$T_{STG}$	- 40	+ 85	°C
Soldering Temperature ( $t_{MAX}$ 3s)	$T_{SOL}$		+250	°C

\* operating close to or outside these conditions may damage the device

### Electro-Optical Characteristics ( $T_{CASE} = 25^{\circ}C$ )

Parameter	Symbol	Values			Unit
		Min.	Typ.	Max.	
Peak Wavelength	$\lambda_P$	965	975	985	nm
Spectral Width (FWHM)	$\Delta\lambda$		0.5	2.0	
Temperature Coefficient	$\alpha$		0.3		nm/°C
Optical Output Power	$P_O$		300		mW
Emitting Aperture	$A$		50x1		$\mu m$
Operating Voltage	$U_F$		1.5		V
Threshold Current	$I_{th}$		60		mA
Operating Current	$I_F$		300		mA
Monitor PD Current	$I_M$		1.0		mA
Slope Efficiency	$\eta$		1.2		W/A
Beam Divergence	parallel x perpend.	$\Theta_{  } \times \Theta_{\perp}$	10x40		deg.



### Electrical Connection

#### Pin Configuration

Pin #	Function
1	LD cathode
2 [case]	LD anode, PD cathode
3	PD anode

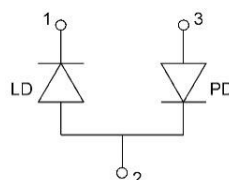

#### Bottom View

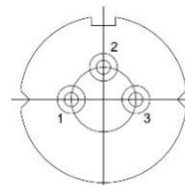



## Outline Dimension

### TO-9

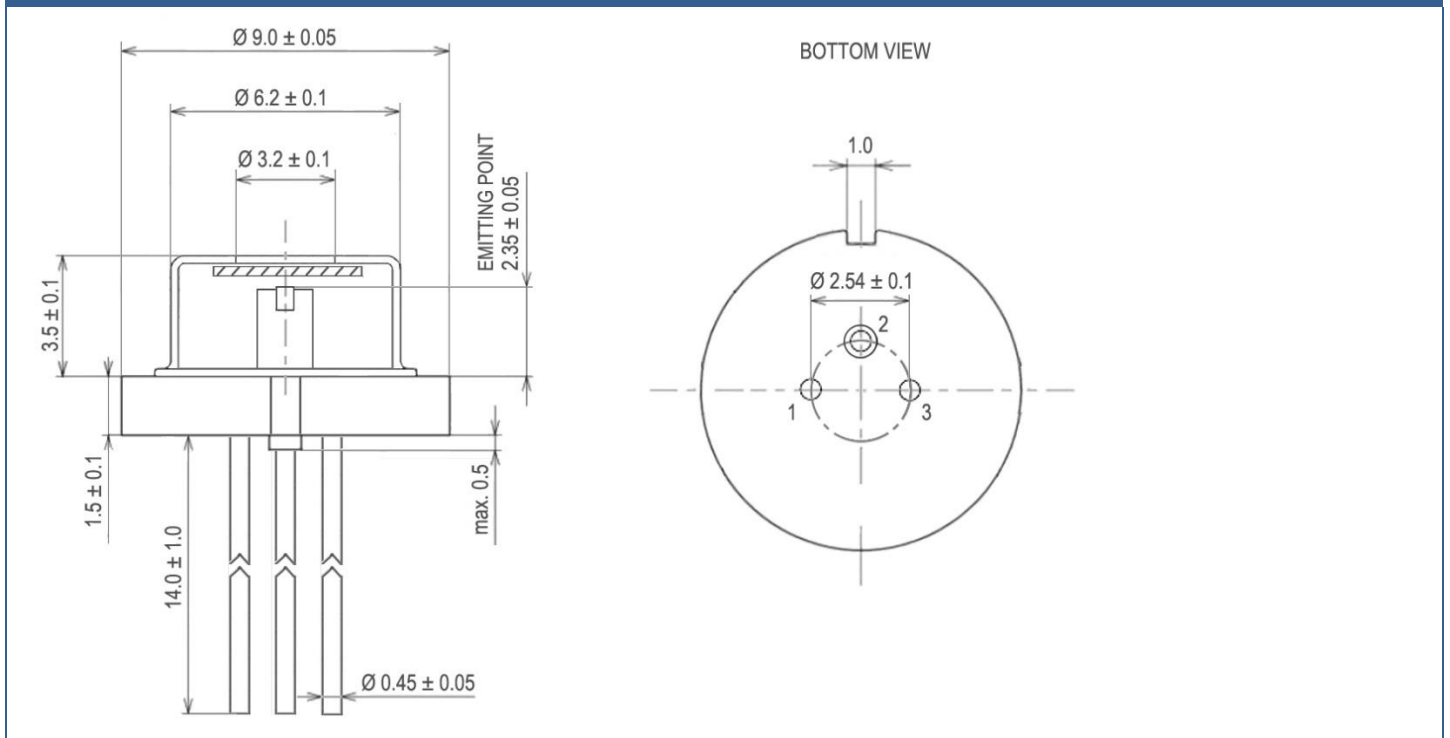

All dimensions in mm

## Precautions

### Safety

**Warning: Invisible laser radiation is emitted from this device!**

**Caution:** Laser light emitted from any laser diode may be **harmful to the human eye**. Avoid looking directly into the laser diode's aperture when the diode is in operation.

**Note:** The use of optical lenses with this laser diode will increase eye hazard

### ESD caution

Always do handle laser diodes with extreme care to **prevent electrostatic discharge**, the primary cause of unexpected diode failure. To prevent ESD related failures, it is strongly advised to always **wearing wrist straps**, and **grounding all applicable work surfaces**, when handling laser diodes

### Operating Considerations

It is strongly advised to only operate this laser diode with a current source. The current of a laser diode is an exponential function of the voltage across it. **Usage of current regulated drive circuits is mandatory**. Laser diodes may be damaged by excessive drive currents or switching transients

It is advised, to operate the laser diode at the lowest temperature possible, and to never exceed maximum specifications as outlined in the datasheet. Device degradation will accelerate with increased temperature. **Proper heat sinking will greatly enhance stability and lifetime of the laser diode**