



ROITHNER LASERTECHNIK GmbH

WIEDNER HAUPTSTRASSE 76
TEL. +43 1 586 52 43 -O. FAX. -44

1040 VIENNA AUSTRIA
OFFICE@ROITHNER-LASER.COM



RLT690-1W-C

- Red Laser Diode
- 690 nm, 1.0 W
- Multi Transverse Mode
- C-Mount



Description



RLT690-1W-C is a red high power CW laser diode, typically emitting at 690 nm. It features multi transverse mode emission and a **maximum operating temperature of 20°C**. RLT690-1W-C comes in C-mount package, and has been designed for industrial application. Fast axis collimation lens (FAC) is optionally available

Maximum Rating*

Parameter	Symbol	Values		Unit
		Min.	Max.	
Reverse Voltage	U_R		2	V
Operating Temperature*	T_{OPR}	+ 10	+ 20	°C
Storage Temperature*	T_{STG}	- 20	+ 80	°C
Soldering Temperature (max. 3s)	T_{SOL}		+ 260	°C

* operating close to or outside these conditions may damage the device

Electro-Optical Characteristics ($T_{CASE} = 20^\circ\text{C}$)

Parameter	Symbol	Values			Unit
		Min.	Typ.	Max.	
Peak Wavelength	λ_P	680	690	700	nm
Optical Output Power	P_O		1.0		W
Spectral Width (FWHM)	λ_Δ		2.0		nm
Recommended Operating Temperature	T_{OPR}			20	°C
Emitting Area			150 x1		μm
Operating Voltage	U_F		2.4		V
Threshold Current	I_{th}		0.5		A
Operating Current	I_F		1.5		A
Temperature Coefficient	α		0.25		nm/°C
Slope Efficiency	η		1.1		W/A
Beam Divergence (FWHM)	parallel		$\Theta_{ }$	8	deg.
	perpendicular		Θ_{\perp}	35	deg.





Outline Dimensions (subject to change)

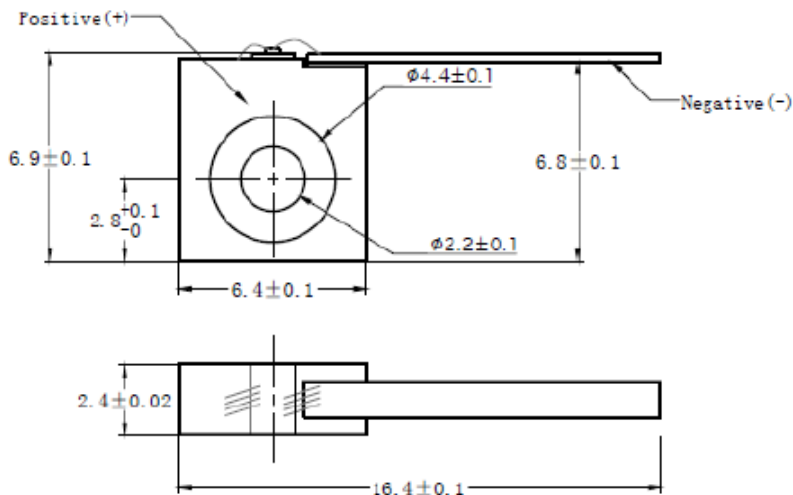

All dimensions in mm

Precautions

Safety

Caution: This laser diode emits highly concentrated light which can be **hazardous to the human eye and skin**. This diode is classified as **CLASS 4 laser product** according to **IEC 60825-1** and **21 CFR Part 1040.10 Safety Standards**.

Note: The use of optical lenses with this laser diode will increase eye hazard

ESD caution

Always do handle laser diodes with extreme care to **prevent electrostatic discharge**, the primary cause of unexpected diode failure. To prevent ESD related failures, it is strongly advised to always **wearing wrist straps**, and **grounding all applicable work surfaces**, when handling laser diodes



Operating Considerations

It is strongly advised to only operate this laser diode with a current source. The current of a laser diode is an exponential function of the voltage across it. **Usage of current regulated drive circuits is mandatory**. Laser diodes may be damaged by excessive drive currents or switching transients

It is advised, to operate the laser diode at the lowest temperature possible, and to never exceed maximum specifications as outlined in the datasheet. Device degradation will accelerate with increased temperature. **Proper heat sinking will greatly enhance stability and life time of the laser diode**