



ROITHNER LASERTECHNIK GmbH

WIEDNER HAUPTSTRASSE 76
TEL. +43 1 586 52 43 -O. FAX. -44

1040 VIENNA AUSTRIA
OFFICE@ROITHNER-LASER.COM



RLT785-1000GOP

- Laser Diode
- 785 nm, 1 W
- Multi-Mode
- 9 mm TO-Can



Description



RLT785-1000GOP is an AIN based **multi-mode** infrared laser diode, typically emitting at **785 nm**, with a nominal output power of **1000 mW**, and wide operating temperature range of up to 50°C. **RLT785-1000GOP** comes in hermetically sealed **9 mm TO-Can** package with AR coated flat glass window.

Maximum Ratings*

Parameter	Symbol	Values		Unit
		Min.	Max.	
Operating Temperature	T_{OPR}	- 20	+ 50	°C
Storage Temperature	T_{STG}	- 40	+ 85	°C
Soldering Temperature (t_{MAX} 3s)	T_{SOL}		+250	°C

* operating close to or outside these conditions may damage the device

Electro-Optical Characteristics ($T_{CASE} = 25^{\circ}C$)

Parameter	Symbol	Values			Unit
		Min.	Typ.	Max.	
Peak Wavelength	λ_P	780	785	790	nm
Optical Output Power	P_O		1		W
Emitting Aperture	A		100		μm
Operating Voltage	V_F		2.0		V
Threshold Current	I_{th}		500	600	mA
Operating Current	I_F		1.5	1.7	A
Slope Efficiency	η		1.0		W/A
Beam Divergence (FWHM)	Parallel	$\Theta_{ }$	12		deg.
	Perpendicular	Θ_{\perp}	30		deg.



Electrical Connection

Pin Configuration		Bottom View	
Pin #	Function		
1	LD cathode		
2 [case]	LD anode		
3	Not connected		





Outline Dimension

TO-9

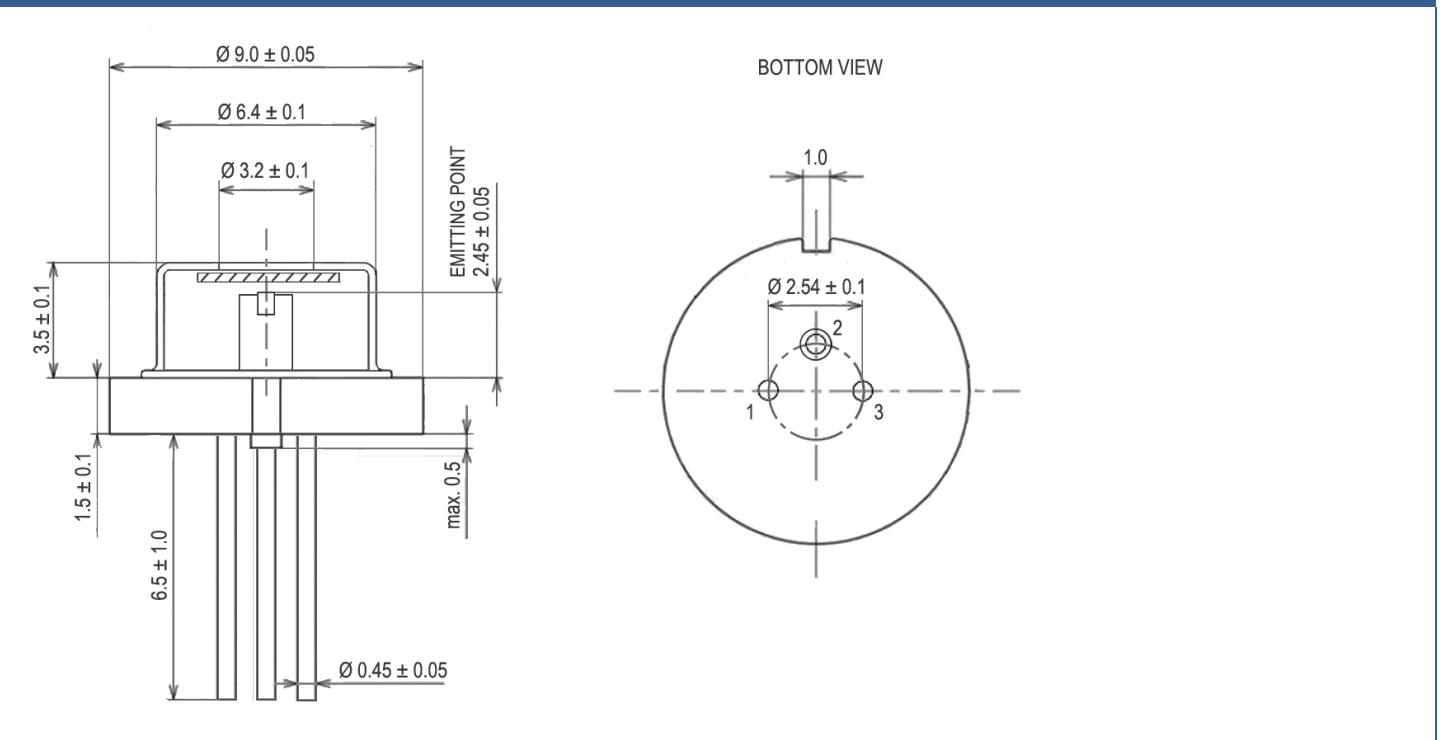

All dimensions in mm

Precautions

Safety

Warning: Invisible laser radiation is emitted from this device!

Caution: Laser light emitted from any laser diode may be **harmful to the human eye**. Avoid looking directly into the laser diode's aperture when the diode is in operation.

Note: The use of optical lenses with this laser diode will increase eye hazard

ESD caution

Always do handle laser diodes with extreme care to **prevent electrostatic discharge**, the primary cause of unexpected diode failure. To prevent ESD related failures, it is strongly advised to always **wearing wrist straps**, and **grounding all applicable work surfaces**, when handling laser diodes

Operating Considerations

It is strongly advised to only operate this laser diode with a current source. The current of a laser diode is an exponential function of the voltage across it. **Usage of current regulated drive circuits is mandatory**. Laser diodes may be damaged by excessive drive currents or switching transients

It is advised, to operate the laser diode at the lowest temperature possible, and to never exceed maximum specifications as outlined in the datasheet. Device degradation will accelerate with increased temperature. **Proper heat sinking will greatly enhance stability and lifetime of the laser diode**